

REVISION BLOCK		
REV	DESCRIPTION	DATE

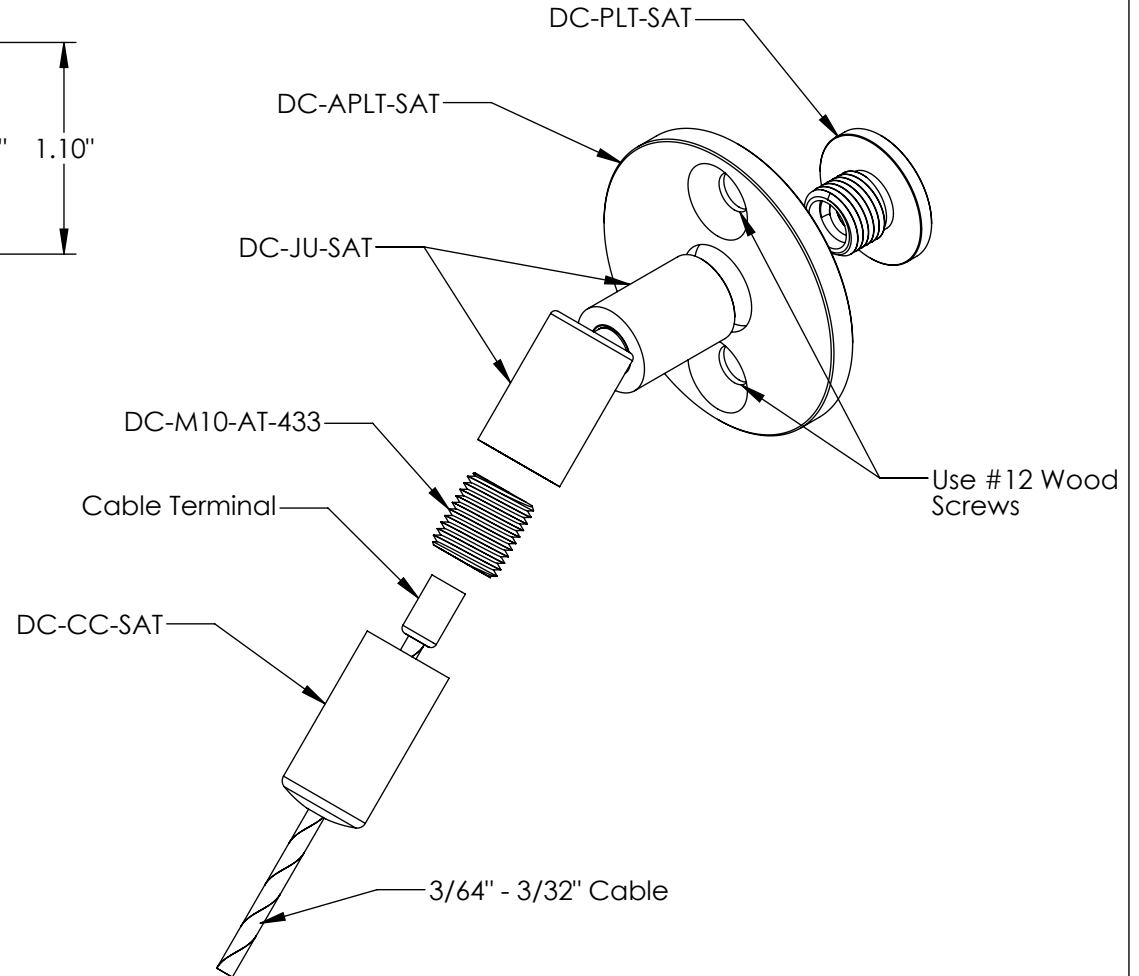

Unless otherwise specified
 1. Dimensions are in inches
 2. Tolerances are:
 .XX ±.01 .XXX ±.005 Angles 1°
 3. Break all edges .005 min
 4. Finish 63 micro inches
 5. Dimensions apply after finish
 6. Concentricity = .025 TIR

PROPRIETARY AND CONFIDENTIAL
 This drawing and these specifications are the exclusive property of GRIPLOCK SYSTEMS INC. and shall not be divulged, reproduced, copied, or used as the basis for the manufacture or sale of apparatus without the express written authorization of GRIPLOCK SYSTEMS INC.

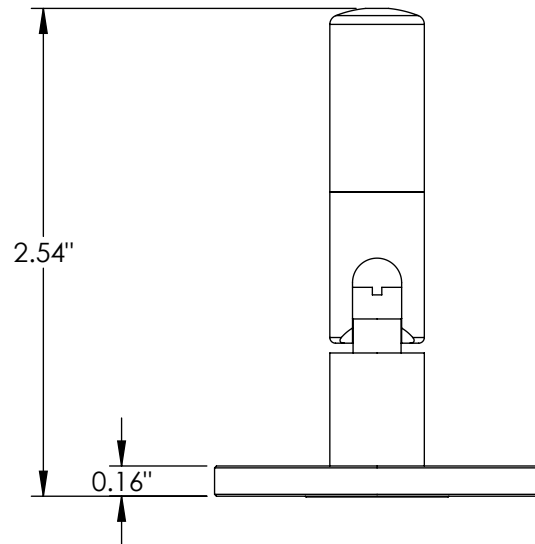
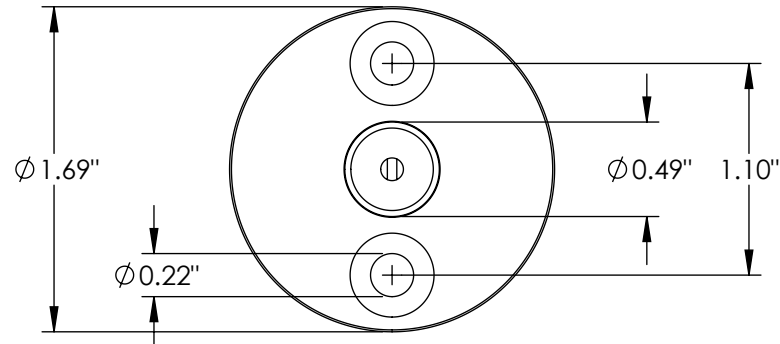

GRIPLOCK SYSTEMS
 793 Duncan Reidville Rd. Duncan, SC 29334
 Phone (805) 566-0064 Fax (805) 566-0065

DRAWN BY RDK REV INT
 CHECKED BY

REF: DATE: 06/26/07
 MATERIAL: SATIN CHROMIUM PLATED BRASS
 SCALE: 1:1 FILE: DG-CC-JU-APLT-SAT c

PART NUMBER: DG-CC-JU-APLT-SAT
 DESCRIPTION: Jointed Coupler w/ Anchor Plate